

QUALITY-BUILT™

powered by:



BRAKE BOOSTER

REFUERZO DE FRENO

SERVOFREIN

Brake Booster



The Smarter Choice

Designed with the professional installer in mind, Quality Built Brake Boosters are engineered and tested to deliver maximum braking assist with minimal pedal effort.

Complete

Quality Built Brake Boosters are installation ready with everything included in the box for a complete repair, full system restoration and safe vehicle operation.

Perfection

Direct OE fit and function, supported by 100% end-of-line testing, for worry-free performance and full restoration of stopping power.

Experience

Backed by over 50 years of engineering know-how, Quality Built Brake Boosters feature design upgrades that improve function and durability.

Support

MPA's ASE-certified Part Smart™ technicians are ready to help get you back on the road with answers for any product, installation, or diagnostic questions.

1. Reliability

OE quality components and 100% check valve replacement for optimal pressure transfer, and safe operation.

2. Confidence

Manufactured and tested to meet or exceed OE performance specifications for durability.

3. Corrosion Resistance

Advanced rust preventatives provide superior protection from the elements and long service life.

4. Hardware Included

New OE specification mounting nuts and washers ensure a complete fix every time.

5. Perfect Fit

Preset master cylinder push rods are easy to install and restores original pedal feel.

6. Good-to-Go

All threaded ports are chased to prevent cross-threading during installation.

7. Verified Performance

All booster units are 100% pressure tested, ensuring leak-free performance.

8. Re-charged

100% re-pressurized nitrogen chambers provide improved stopping in panic or emergency situations.

Product Detail



Quality-Built Brake Boosters provide reliable pressure transfer and confident braking power. All units are subjected to 100% end-of-line tested for worry-free performance right out of the box.

QUALITY-BUILT™

powered by:



HUBS AND BEARINGS | BUJES Y RODAMIENTOS | MOYEUX ET ROULEMENTS

Hubs and Bearings



The Smarter Choice

With industry leading coverage and engineered product enhancements, Quality Built Hub Assemblies meet the demands of professional installers.

Complete

Quality Built Hub Assemblies are installation ready right out of the box with everything included to get the job done, and restore safe vehicle operation.

Perfection

Direct OE replacement parts engineered, manufactured, and tested to meet or exceed factory specifications for performance and durability.

Experience

Quality Built Hub Assemblies feature engineered improvements designed to maximize performance, reduce noise and maximize service life.

Support

MPA's ASE-certified Part Smart™ technicians are ready to help get you back on the road with answers for any product, installation, or diagnostic questions.

1. Application-Specific

OE designs and materials are provide like-new performance and durability for miles to come.

2. Heavy Duty Seals

Protect internal bearings and components from water, dust, and external debris.

3. Smooth Operation

High-temperature, aerospace grade grease reduces friction and eliminates noise.

4. Precision Bearings

Prevents excessive run out, improves internal tolerance accuracy, and improves load bearing capacity.

5. Raceways

Induction hardened, micro-finished races improve bearing durability and load capacity.

6. Wheel Studs

100% new OE style wheel studs where required.

7. High-Carbon Steel

Premium, high-carbon steel alloys improve load bearing capabilities and strength.

8. ABS Sensors

Application-specific ABS sensors included for perfect vehicle control system signaling.

Product Detail

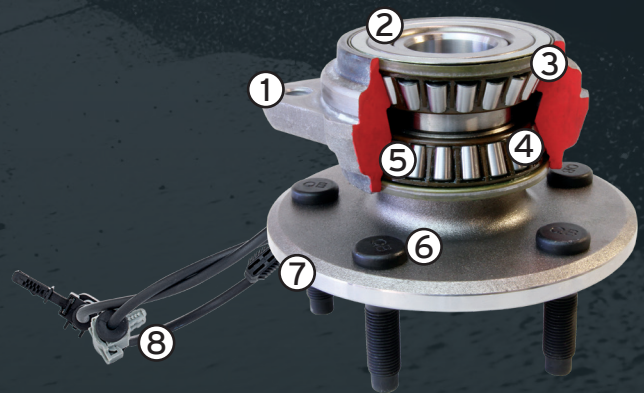

Quality-Built Hub Assemblies are built to exacting specifications and use only premium materials, so they can handle the demands put on them by today's vehicles.

QUALITY-BUILT™

BRAKE CALIPER

ÉTRIER DE FREIN

PINZA DE FRENO

powered by:



Brake Caliper



REMAN



99% Vehicle Coverage
Legendary MPA Fill Rates and Quality
Market, & Category Management Support
Technical Support
Product Training Programs

The Smarter Choice

Quality-Built Brake Calipers are manufactured to meet the demands of professional installers with industry leading application coverage, and unmatched quality

Complete

Quality-Built Brake Calipers are installation-ready with everything included in the box for a complete repair, ensuring full restoration and safe vehicle operation.

Perfection

Quality-Built Brake Calipers are direct OE replacement parts engineered and manufactured to meet or exceed factory specifications for performance and durability.

Experience

100% End-of-Line verification using proprietary, computer-controlled hydraulic testers ensures leak-free performance right out of the box.

Support

MPA's ASE-certified Part Smart™ technicians are ready to help get you back on the road with answers for any product, installation, or diagnostic questions.

1. Brackets Included

Application specific brackets prevent caliper binding and take the guesswork out of caliper replacement.

2. Rust Prevention

OE style zinc plating rust preventatives ensure long caliper life and restores factory appearance.

3. 100% Tested

Pressure testing checks every seal, bleeder, and line connection for leak-free operation.

4. Good-to-Go

All threaded ports are chased to prevent cross-threading during installation.

5. All New Dust Boots and Seals

EPDM rubber components are more resistant to deterioration caused by extreme temperatures.

6. Hardware Included

Application specific abutment hardware provides correct pad fitment in the caliper body.

7. All New Phenolic Pistons

To ensure maximum durability and reliability all phenolic pistons are replaced.

8. Perfect Connection

All new banjo bolts and crush washers for a perfect leak-free seal.

Product Detail

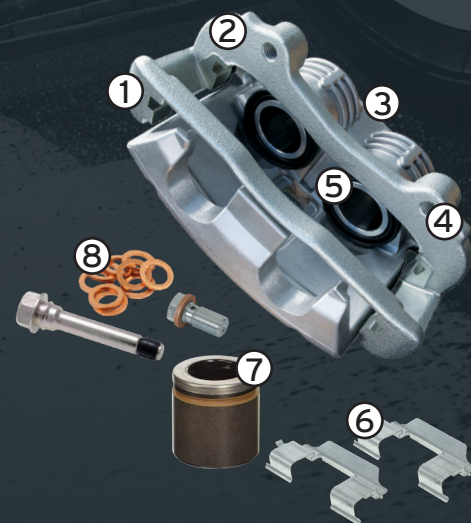

Quality-Built calipers are zinc plated for maximum protection, from the elements. Each caliper unit comes installation ready with new bleeder screws, banjo bolts and application-specific hardware where required.

QUALITY-BUILT™

STARTER | DÉMARREUR | MOTOR DE ARRANQUE

powered by:



Starter



NEW



REMAN



The Smarter Choice

With industry leading vehicle coverage and TS16949 certified manufacturing facilities, Quality Built is the most complete starter program available in the aftermarket.

Complete

Quality Built Starters are installation-ready with everything included in the box for a complete repair, ensuring full restoration and safe vehicle operation.

Perfection

Quality Built Starters are direct OE replacement parts engineered and manufactured to meet or exceed factory specifications for performance and durability.

Experience

Rigorous three-phase testing, including 100% End-of-Line verification using proprietary, computer-controlled testers, ensure worry-free performance.

Support

MPA's ASE-certified Part Smart™ technicians are ready to help get you back on the road with answers for any product, installation, or diagnostic questions.

1. Starter Drives

Application-specific starter drive gears are inspected and replaced as required.

2. Bearings

100% new premium, sealed bearings increase durability and service life.

3. Starter Drive Clutch

Remanufactured with aerospace quality lubricants for smooth energy transfer to the flywheel.

4. Armature

Armatures are inspected and tested to meet or exceed OE output performance specifications.

5. Commutator

Are inspected and precision machined for maximum contact and optimized voltage transfer.

6. Brushes

100% new, lead-free brushes increase conductivity and reduce contact resistance.

7. Solenoid

Solenoids are inspected and tested to meet or exceed OE output performance specifications.

8. Solenoid Contacts

100% new solenoid contacts for maximum cranking power.

Product Detail

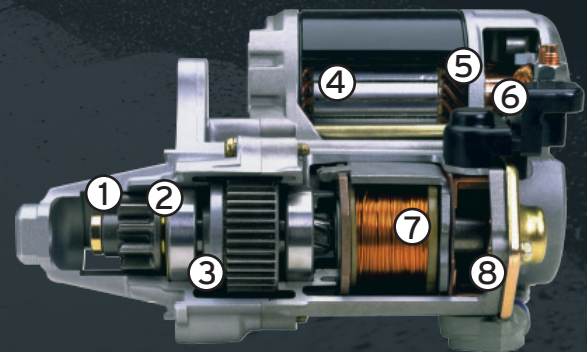

Quality-Built new and remanufactured starters are engineered, and durability tested in real-world simulations to provide confident, durable cranking power every time.

QUALITY-BUILT™

ALTERNATOR | ALTERNATEUR | ALTERNADOR

powered by:



Alternator



The Smarter Choice

With unmatched quality the best coverage in the aftermarket, Quality Built is the brand technicians trust when it comes to replacement alternators.

Complete

Quality Built Alternators are installation-ready with everything included in the box for a complete repair, ensuring full restoration and safe vehicle operation.

Perfection

Quality Built Alternators are direct OE replacement parts engineered and manufactured to meet or exceed factory specifications for performance and durability.

Experience

Rigorous three-phase testing, including 100% End-of-Line verification using proprietary, computer-controlled testers, ensure worry-free performance.

Support

MPA's ASE-certified Part Smart™ technicians are ready to help get you back on the road with answers for any product, installation, or diagnostic questions.

1. Pulley

Clutch and decoupler designs are remanufactured and set to OE specification for like-new operation.

2. Bearings

100% new premium, sealed bearings increase durability and service life.

3. Rotor

Multi-phase tested and double coated for maximum corrosion protection.

4. Stator

Stators are inspected and tested to meet or exceed OE output specifications.

5. Slip Ring

Precision polishing provides consistent voltage output and reduced wear on brushes.

6. Brushes

100% new, brushes for optimal conductivity and reduced contact resistance.

7. Voltage Regulator

Variable load testing ensures correct voltage delivery at all RPM's.

8. Rectifier

100% new, press fit, high capacity diodes maximize current output flow.

Product Detail

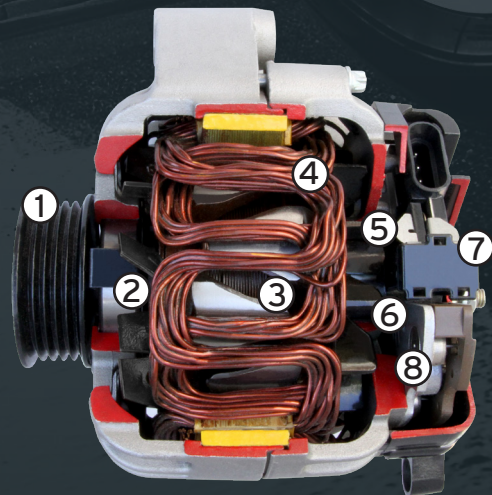

Quality-Built new and remanufactured alternators are assembled from premium materials and 100% end-of-line certified to meet or exceed OE specifications for performance and reliability.

QUALITY-BUILT™

powered by:



MASTER CYLINDERS | MAÎTRES-CYLINDRES | CILINDROS MAESTROS

Master Cylinders



Quality Built to Last

Quality Built Brake Master Cylinders are engineered and manufactured for dependable performance, maximum durability and easy installation.

Complete

Quality Built Brake Master Cylinders are installation ready with everything included in the box for a complete repair, full system restoration and safe vehicle operation.

Perfection

Direct OE fit and function, supported by 100% end-of-line testing, for worry-free performance and full restoration of stopping power.

Experience

Backed by over 50 years of engineering know-how, Quality Built Brake Master Cylinders feature design upgrades that improve function and durability.

Support

MPA's ASE-certified Part Smart™ technicians are ready to help get you back on the road with answers for any product, installation, or diagnostic questions.

1. Caps and Floats

Replacement caps and float switches included where applicable.

2. Reservoirs

Constructed from durable high-strength plastic for improved resistance to thermal fatigue and failure.

3. New Switches

New negative ground switches eliminate potentially faulty sensors, eliminating and future service requirements.

4. OE Fit and Function

OE materials and manufacturing process for a perfect fit and easy installation.

5. Precision Machining

Micro-finished bores and pistons provide smooth, consistent pedal feel and stopping power.

6. Ready for Anything

All master cylinder units are 100% pressure tested on computerized equipment for optimal performance.

7. Dependability

100% New EPDM Seals and O-Rings maintain consistent brake pressures for safe stopping power.

8. Quality Control

Strict manufacturing quality-control standards and full end-of-line quality inspections eliminate defects.

Product Detail

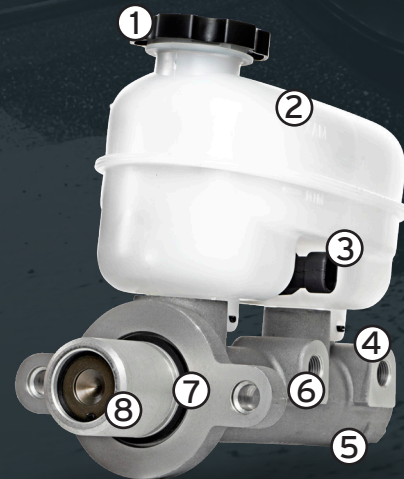

Quality-Built new and remanufactured alternators are assembled from premium materials and 100% end-of-line certified to meet or exceed OE specifications for performance and reliability.